

easee

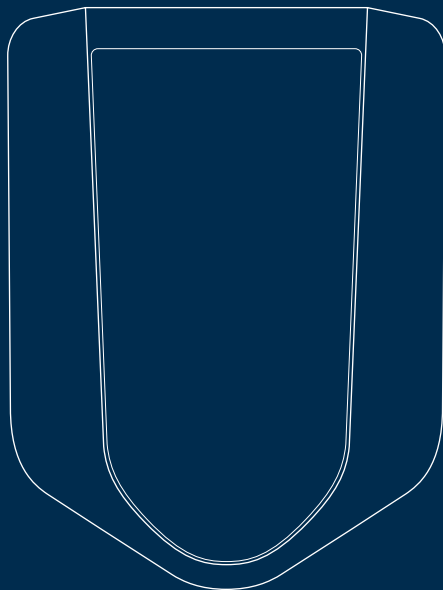

User guide / Installation guide

# Easee Ready

# Table of contents

## **Introduction**

Introduction	3
Product overview	4
Technical specifications	4

---

## **Safety**

Safety instructions	5
---------------------	---

---

## **Before the installation**

Planning the installation	6
---------------------------	---

---

## **Installation**

Installation instructions	8
---------------------------	---

---

## **Daily use and operation**

Maintenance	14
Practical details	14

### **IMPORTANT:**

Read carefully before use. Keep for future reference.

# Introduction

The Easee Ready includes a backplate and a blind cover. By installing it you can extend your charging infrastructure at any time in the future. This is easily done with the Easee Plug & Play product by mounting the new Chargeberry in the empty Easee Ready backplate without the need of an electrician.

## Intended use

This product is intended solely as a prepared charging point for an Easee Charging Robot.

The product must be firmly mounted on a wall or structure that covers the entire back side of the product and has a sufficient load-bearing capacity. It may only be operated with the approved operating parameters and under the specified environmental conditions (see page 5).

Uses other than those specified here are not permitted.

## Conventions



This symbol indicates that the respective instructions must only be carried out by an authorised electrician.



This symbol indicates an immediate danger to life and health of individuals due to the effects of electrical energy. Non-observance of these instructions will result in serious damage to health – up to and including life-threatening injuries.

# Product overview

## Blind cover

Protects the electrical connections from external influences.

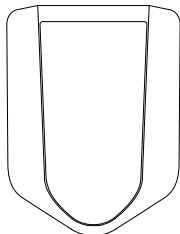

## Backplate

For attaching and connecting to the charging infrastructure.

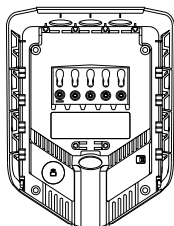

## Tool

Used for removing the blind cover, after the screw has been removed.



x1

## Installation kit



x2



x3



x2



x5



x4

# Technical specifications

## General

Dimension (mm): H: 256 x W: 193 x D: 78

Wall mounting (mm): c/c H: 160 x W: 125

Colour: Black

Installation kit included

## Wire terminals

Wire cross-section: up to 16 mm<sup>2</sup> (single cable)/ up to 10 mm<sup>2</sup> (parallel connection)

Cable diameter: 8–22 mm

Terminal torque: 5 Nm

Cable strip length: 12 mm

## Installation

Installation network: TN, IT or TT

Installation circuit breaker: Max 40 A (Easee Home) or max 80 A (Easee Charge) overload protection. The short-circuit current at the charging point (IkMax) must not exceed 10 kA. If required by the installation, type-A earth fault protection can be used for the circuit.

## Protection

Degree of protection: IP44

Impact resistance: IK08

Fire class: UL94

# Safety instructions

**Read the entire manual carefully before installing and operating the product. Observe the following instructions:**

## **Safety instructions for the installation**

- This product shall only be installed, repaired or serviced by an authorised electrician. All applicable local, regional and national regulations for electrical installations must be respected.
- Danger to life due to high electrical voltage. Never make any changes to components or connecting cables.
- The installation must not be carried out in the vicinity of explosive atmospheres or in areas where there is a risk of flowing water.
- The product must be installed on a permanent location. The connections of the backplate are designed for a limited number of plugging cycles.
- The product must be installed on a wall or structure with sufficient load bearing capacity.
- The product must always be installed on a surface that covers the entire back side area of the product.
- The terminals in the backplate are energised when the power circuit is closed and must never be in direct contact or in contact with anything other than the plug-in electronics (Chargeberry).

## **Safety instructions for operation**

- Danger to life due to high electrical voltage. Never make any changes to components, software or connecting cables.
- Never use or touch the product if it is damaged or does not function properly.
- Always have the prescribed maintenance, installation and any repair work carried out by an authorised electrician and in accordance with local requirements.
- If a fire occurs, do not use water for extinguishing.
- Never clean the product with high pressure or running water.
- Do not immerse the product in water or other liquids.
- Make sure that children do not play with the product.
- Even if the product is designed to withstand normal weather conditions, we recommend protecting it from direct sunlight or exposure to extreme weather conditions.

# Planning the installation



**WARNING!** This product shall only be installed, repaired or serviced by an authorised electrician. All applicable local, regional and national regulations for electrical installations must be respected.

Prior to the installation, it is recommended that you consider future charging needs, so that you can easily expand accordingly in the future.

If several Charging Robots are connected to the same circuit, the total current is dynamically distributed between them. The connected Charging Robots communicate wirelessly between themselves, ensuring that the specified total current of the charging infrastructure is not exceeded. The maximum charging current is set during configuration.

## Check the following before starting the installation

- Where should the Easee Ready be installed?
- Is the connected electrical load of the building sufficient or does it need to be increased? Does a new cable have to be laid? (An external approval may be required). Should the incoming supply cable be upgraded?
- How is the electrical circuit protected?
- Which installation method is planned to be used?

## Pay attention to the following when planning the installation

- The correct selection of the grounding/earthing system, conductors and protective measures (basic protection/ fault protection).
- The correct insulation of touchable and conductive parts.
- Sufficient dimensioning of cables.
- The selection of the overcurrent and overvoltage protection.
- The correct calculation of the short-circuit current as well as a short-circuit proof installation method.

## Residual Current Device (RCD)

A Residual Current Device (RCD), according to EN 61008-1 and IEC 62955, is integrated in the Charging Robot.

The integrated RCD has no influence on the function of external protective devices. If a Class II installation is supplying the Charging Robot(s), no external RCD is normally required. Local wiring regulations must however always be followed.

## For an optimal result, we recommend that you do the following

- We always recommend a 3 phase installation if possible, to make it future-proof.
- If possible, use the largest approved cable cross-section (see page 4).

## Special notes for Charging Robot

- In addition to the integrated residual current device (RCD), an overload protection is integrated in the Charging Robots.
- Several backplates can be connected in parallel, as each Charging Robot has its own protective device.
- The Charging Robots can handle a maximum short-circuit current (I<sub>pk, max</sub>) of 10 kA. When surveying the installation, it must be checked whether further

protection should be provided.

- If the charging infrastructure includes more than one Charging Robot, the backplate that is configured first becomes the master of its circuit.
- If more than 2 units are installed, the master unit should be located in the middle of the installation (if possible) for an optimal Easee Link communication.

#### Technical notes for Easee Home installation

- The circuit with one or more Charging Robots can be fused up to 40 A as long as the maximum short-circuit current (I<sub>pk</sub>, max) of 10 kA is not exceeded.
- A maximum of 3 Charging Robots on the same circuit is supported with Easee Home.

#### Technical notes for Easee Charge installation

- The circuit with one or more Charging Robots can be fused up to 80 A as long as the maximum short-circuit current (I<sub>pk</sub>, max) of 10 kA is not exceeded.
- A maximum of 101 Charging Robots on the same circuit (fuse) is supported with Easee Charge.
- **Site Key:** During installation, a Site Key must be used to assign the Charging Robots to the correct location in the Easee Cloud. A Site Key will automatically be generated when creating a new charging site using the Easee Installer app or it can be obtained by creating a new charging site at [easee.cloud](https://easee.cloud).

#### Your house, power grid and EV

The Charging Robot automatically adapts to the power grid, the electric car and the capacity of the electrical installation. In the diagram below you can see what charging effect you can expect from your installation and situation. The table below is only meant as a guide.

**NOTICE!** The type of installation as well as cable cross-sections must be determined by a qualified electrician in accordance with valid local, regional and national regulations for electrical systems.

Load	Charging power	
Ampere (A)	1 phase (kW)	3 phase (kW) <sup>1</sup>
6	1.4	4.1
8	1.8	5.5
10	2.3	6.9
13	3.0	9
16	3.7	11
20	4.6	13.8
25	5.8	17.3
32	7.4	22

<sup>1</sup> Example for 400 V TN, deviating values for other grid types.

# Installation instructions



**WARNING!** This product shall only be installed, repaired or serviced by an authorised electrician. All applicable local, regional and national regulations for electrical installations must be respected.



**WARNING!** Turn off the power before you begin the wiring. Use extreme caution and follow instructions carefully.



In addition to the instructions presented on the next pages, we recommend that you watch the installation videos available on our website: [easee.support](http://easee.support).

## 1 Easee Ready Opening

**WARNING!** Be sure to read the safety instructions (page 5) of this product before you start the installation.

1. Unscrew the locking screw at the bottom of the Easee Ready.
2. Insert the two ends of the included tool into the two openings at the bottom of the Easee Ready cover.
3. Pull until the cover comes loose.
4. Lift the cover from the bottom and upwards.

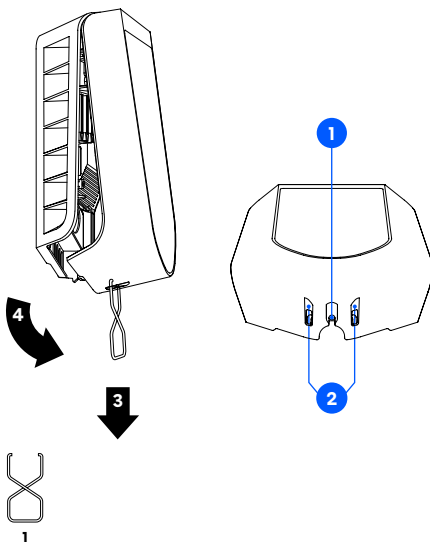



## 2 Backplate Mounting

1. Fix the backplate to a wall or structure with sufficient load-bearing capacity using the 4 screws provided in the mounting kit. Use suitable wall plugs for mounting and observe the recommended installation height (see below).
2. Turn off the power before proceeding with the installation.

**NOTICE!** If you are going to install multiple backplates, now would be a good time to mount them as well.

**IMPORTANT!** The installation wall must cover the entire back of the product.

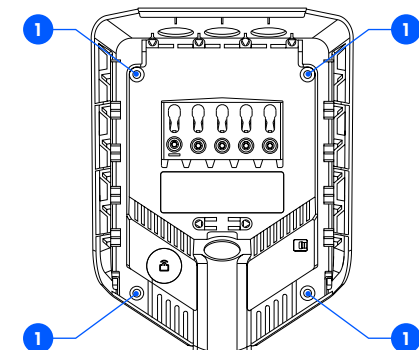

130-140 cm

Recommended installation height

## 3 Backplate Preparing

1. Shorten the sealing plug to fit the cable. The hole should be slightly smaller to ensure a good seal.
2. Insert the cable through one of the 4 cable entries and secure it to the backplate with the strain relief provided.
3. Close all cable entries that are not in use with the blind sealing plugs supplied.

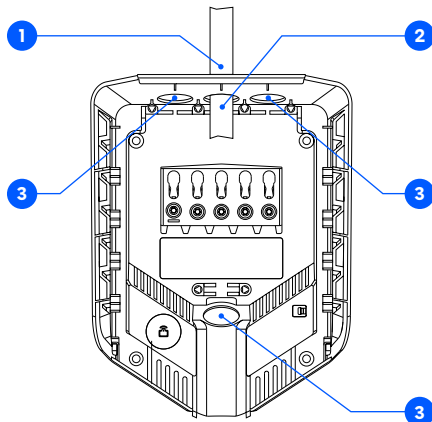

# 4 Backplate Wiring

1. Strip the individual wires by 12 mm. If the cable has flexible conductors, it is recommended to use ferrules on stranded wires. Use correct tools to press them.
2. Tighten the screws with a torque of 5 Nm.

**NOTICE!** After tightening the screws, pull each wire to double check that they are connected properly.

**NOTICE!** When connecting multiple backplates in parallel, each terminal serves as a coupling point for adjacent backplates. All backplates must be connected with the same phase sequence. External junction boxes or flat cables can be used if it is more convenient.

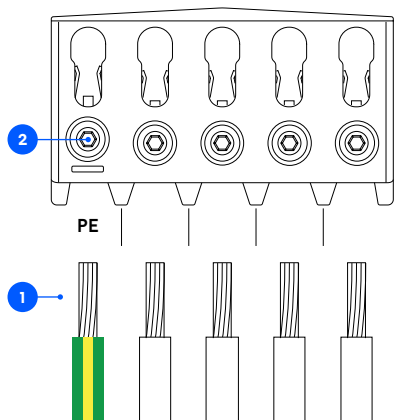

TN/TT 3-phase (230/400 V)

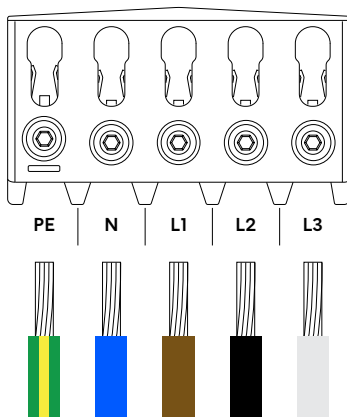

TN 1-phase (230 V)

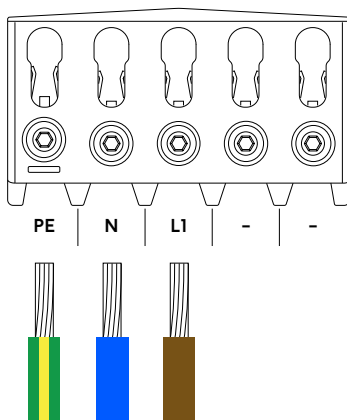

### IT/TT 3-phase (230 V)

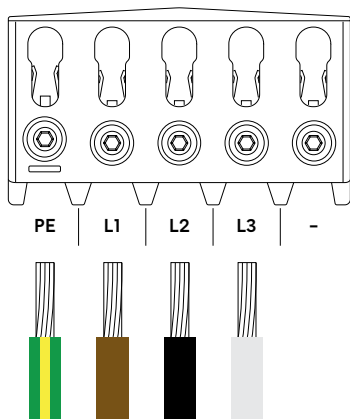

### IT/TT 1-phase (230 V)

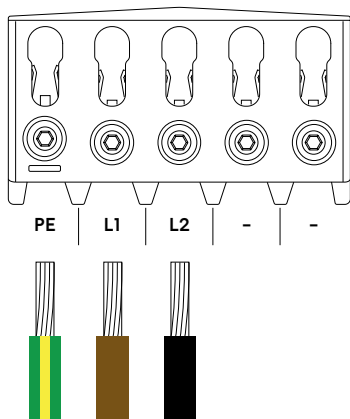

**NOTICE!** It's recommended to follow the existing colour codes used in the installation. Depending on national standards, the colours of the cables can vary from the illustrations. The illustrations in this manual follow the IEC 60446 standard.

**NOTICE!** Before turning on the power, make sure the wires are properly connected and tightened. Test this by pulling on each wire.

# 5 Backplate Installing

1. Scan the QR code to download the Easee Installer App and create a free account. The app is available on App Store and Google Play.

**NOTICE!** Your phone needs to support NFC.

2. Select one of the three site setups in the Installer App:

**Create new site:** If this is a completely new charging site, select "Create new site". Enter the installation details and follow the on-screen instructions.



**Ongoing sites:** If you have an incompletd site, e.g. with missing information or not uploaded to the Cloud, go to "Ongoing sites" and complete them.

**Update existing site:** If this site already has one or more Charging Robots installed or if it has been created by an operator (Easee Charge), select "Update existing site" and search for the site address. On "Site overview", select the circuit that you want the backplate to be part of and select "Add another backplate". Follow the on-screen instructions.

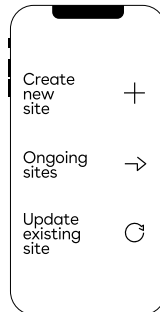

# 6 Blind cover

## Closing

1. Hang the blind cover at the top of the backplate and let it fall into place.
2. Press the bottom of the blind cover until you hear a click.
3. Screw in the locking screw at the bottom of the backplate to secure the blind cover.

**Your Easee Ready is now installed!**

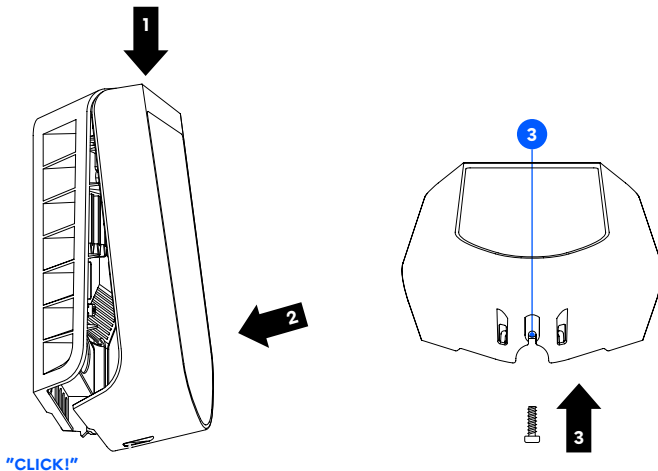

# Maintenance

## General maintenance

If the product is installed in public spaces and is accessible to everyone, observe local and national requirements (e.g. Norway NEK400 part 6.1) in addition to the procedures below.

## Cleaning

The product does not require cleaning to operate properly. Nevertheless, if the product needs to be cleaned for cosmetic reasons, this is possible.

- Use a damp cloth and an all-purpose household cleaner. Avoid using strong chemicals that contain oil or alcohol, as this will discolour the plastic.
- Do not use running water or high pressure water jets.

## Insulation testing (authorised electrician only)



When carrying out periodic insulation testing of a charging circuit, it is recommended that you remove the Chargeberry from its backplate before measuring between all phases joined together towards earth. Testing the circuit insulation with the Chargeberry installed in the backplate may damage the electronics or impact the reading negatively.

# Practical details

## Warranty

The device is free from material defects and is in accordance with laws and regulations for consumer protection in the country where the product is purchased. All correctly installed Easee hardware is covered by our 3 years limited warranty. Further information can be found at [easee.support](https://www.easee.com/support).

## Safety

The product shall be installed according to local regulations for low voltage electrical installations.

## When completely installed and fitted with a Chargeberry

**Standards:** Hereby, Easee AS declares that this product, Easee Ready, is in compliance with the Low Voltage Directive 2014/35/EU and RoHS Directive 2011/65/EU.

The full text of the EU Declaration of Conformity is available at the following internet address: [easee.support](https://www.easee.com/support).

## Product life cycle

**Transportation:** The product should always be transported within its original packaging. No other items should be stored on top of the box other than Easee chargers. Should the box be dropped or otherwise impacted, a visual inspection should be done in order to verify potential damage.

**Storage:** To preserve the packaging and its contents, we recommend storage in a tempered, dry and well-ventilated area. Relative humidity should not exceed 80% and no corrosive gas should be present. Storage or transportation environment should never exceed the limits provided in the technical specifications of the Easee Ready (see page 4).

**Dismounting:** Dismounting shall only be performed by an authorised electrician. The power supply to the charger must be isolated before dismounting starts. Use the installation guide and follow the steps in reverse in order to dismount the Easee Ready in the correct order.



**Disposal:** This electronic equipment must not be disposed of in household waste. For the return of old devices, free collection and acceptance points may be available in your vicinity. Observe local regulations for correct and environmentally friendly disposal. If the old electronic equipment contains personal data, you are responsible for deleting it yourself before returning it.

## Data protection

When the product connects to the Internet, personal data is sent to Easee AS. You will receive more information about data protection during the configuration of your product.

## Repair

If your product needs to be repaired, please contact your Easee supplier.

## Returns and complaints

Contact your distributor or Easee Customer Support regarding the return and complaint of your product.

## Customer support

Download the latest manuals, find answers to frequently asked questions and useful documents and videos for your product at [easee.support](https://easee.support).

## Contact details

Easee AS  
Grønseveien 19  
4313 Sandnes, Norway  
Org. nr: 920 292 046

You can find additional contact details for your country at [easee.com](https://easee.com).

THIS DOCUMENT CONTAINS INFORMATION THAT IS  
SUBJECT TO CHANGE WITHOUT NOTICE.

The latest version of this publication can be downloaded  
at <http://easee.support>

No part of this publication may be reproduced or  
transmitted in any form or by any means, electronic  
or mechanical, including, but not limited to, copying,  
recording, retrieving data, or computer networks without  
the written permission of Easee AS.

Easee and all other Easee product names and slogans  
are trademarks or registered trademarks of Easee AS.  
Easee products can be protected by one or more  
patents.

All other products and services mentioned may be  
trademarks or service marks of their respective owners.

Illustrations of the product and user interface are  
exemplary and may differ from the actual appearance.

October 2021 - Version 1.02

© 2021 by Easee AS. All rights reserved.





---

easee

Easee AS  
Grenseveien 19  
4313 Sandnes, Norway  
[www.easee.com](http://www.easee.com)